

550 Series 600 TVL Analog Dome Cameras (White and Black)



The WPS-550-DOM-A Day/Night Outdoor Varifocal Domes are a versatile option for any surveillance application, equipped with enhanced resolution, improved performance, maximum visibility, and vandal-resistance. They're perfect for general surveillance in retail spaces, offices, restaurants, and under-eave mounting areas.

Features



High-Resolution



IR/Sense-Up



Outdoor-Rated



Adjustable Lens



D-WDR

Provides Crisp, Clear Images

Uses Digital Wide Dynamic Range (D-WDR) to create even lighting and clear images in areas with lots of natural light, and features a digital signal processor that produces crisp, clean pictures.

Sees in the Dark

Features Smart IR to eliminate overexposure and evenly illuminate subjects so they can be seen clearly even in the dark.

Compensates for All Kinds of Lighting

Whether dealing with background or foreground space, bright lights or dark areas, LED intensity or uneven contrast, this camera is equipped with a slew of technology to handle it all – and produce crystal-clear, easily-identifiable images.

Keeps Designated Areas Private

Blocks out sensitive or privileged areas defined by users to ensure privacy of controlled access areas or home interiors.



5-Year Limited Warranty

This camera has a 5-Year Limited Warranty. The warranty includes parts and labor repairs on all components found to be defective in material or workmanship under normal conditions of use. This warranty shall not apply to products which have been abused, modified, disassembled or improperly installed. Products to be repaired under this warranty must be returned to Snap AV or a designated service center with prior notification and an assigned return authorization number (RA).

550 Series 600 TVL Analog Dome Cameras (White and Black)

DIMENSIONS

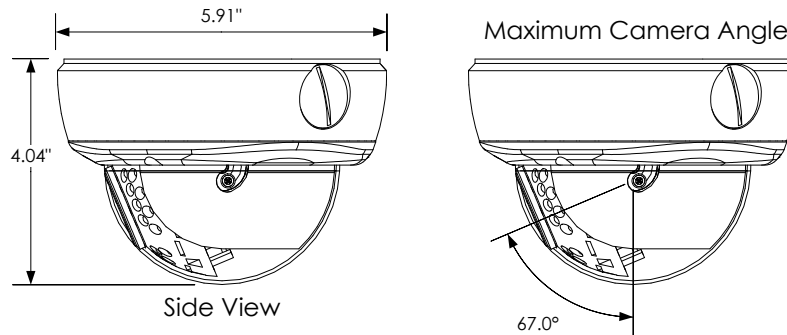

SPECIFICATIONS

Video	Image Sensor	1/3" Sony Super-HAD II CCD
	Effective Number of Pixels	NTSC: 768(H) * 494(V)
	Resolution	Color: 600 TVL; B/W: 650 TVL
	Min. Illumination	Color: 0.01 Lux (F1.2), 0.0001 Lux
	Gamma	0.45
	S/N Ratio	52dB (AGC Off)
	BNC Video Output	1.0 Vp-p, 75 ohm
	Sync Mode	Internal sync
	Scanning System	2:1 Interlace
	Horizontal Sync. Frequency	NTSC: 15.734 KHz
	Shutter Control	Auto: 1/60(50)~1/100000 sec.
	Auto Gain Control	On (Level Programmable) / Off
	Back Light Compensation	HLC / BLC / Off
	White Balance	ATW1, ATW2, AWC-SET, MANUAL
	Day/Night	Color, B/W (IR SMART), AUTO, EXT
	Privacy Masking	On (8 Programmable Areas) / Off
	Motion Detection	4 Programmable Areas / Off
	Mirror	On / Off
	2D-DNR	On / Off
	DWDR	On (Level Programmable) / Off

Video	Parking Line	On / Off
	Camera ID	Programmable
	Lens Shading	On / Off
	Dead Pixel Compensation	AUTO (64 points)
	RS-485	PELCO-D / PELCO-P
	OSD	Yes
	Smart IR	Yes
	Sharpness	On (Level Programmable) / Off
	Infrared LED	Quantity
Radiant Distance		65 ft.
Power	Power Supply	12-30 VDC (1A) or 24 VAC (500mA) - not included
	Power Consumption	4.5W 375 mA
Lens	Size	3.7 ~ 12mm Varifocal Auto Iris Lens
	Field of View- Horizontal	76.9 ° (W) ~ 22.7 ° (T)
	Field of View- Vertical	56.89 ° (W) ~ 17.07 ° (T)
Weatherproof	IP 66 Grade	
Certifications	CE, FCC, ROHS	
Net Weight	2 lbs (890 Grams)	
Dimensions	4.04" (H) x 5.91" (W)	
Operating Temperature	14°F ~ 140°F / 80% RH	

5-Year Limited Warranty

This camera has a 5-Year Limited Warranty. The warranty includes parts and labor repairs on all components found to be defective in material or workmanship under normal conditions of use. This warranty shall not apply to products which have been abused, modified, disassembled or improperly installed. Products to be repaired under this warranty must be returned to Snap AV or a designated service center with prior notification and an assigned return authorization number (RA).