

350 Series 550 TVL Analog Dome Cameras (White and Black)



These WPS-350-DOM-A Indoor/Outdoor Dome Cameras are perfect for retail spaces, restaurants, offices, and residential applications, delivering incredible picture quality and installation flexibility. Features enhanced resolution and an adjustable field of view to meet many general surveillance needs.

Features



High-Resolution



IR/Sense-Up



Outdoor-Rated



Adjustable Lens



Vandal Resistant

Provides Crisp, Clear Images

Focuses clearly on people and objects of interest with its high-quality lens, enhanced video resolution, and adjustable field of view.

Sees in the Dark

Features Smart IR to eliminate overexposure and evenly illuminate subjects so they can be seen clearly even in the dark.

Compensates for Bright Backgrounds

Reduces silhouetting so foreground subjects can be seen clearly, even when there are bright background lights in the picture.

Keeps Designated Areas Private

Blocks out sensitive or privileged areas defined by users to ensure privacy of controlled access areas or home interiors.



5-Year Limited Warranty

This camera has a 5-Year Limited Warranty. The warranty includes parts and labor repairs on all components found to be defective in material or workmanship under normal conditions of use. This warranty shall not apply to products which have been abused, modified, disassembled or improperly installed. Products to be repaired under this warranty must be returned to Snap AV or a designated service center with prior notification and an assigned return authorization number (RA).

350 Series 550 TVL Analog Dome Cameras (White and Black)

DIMENSIONS

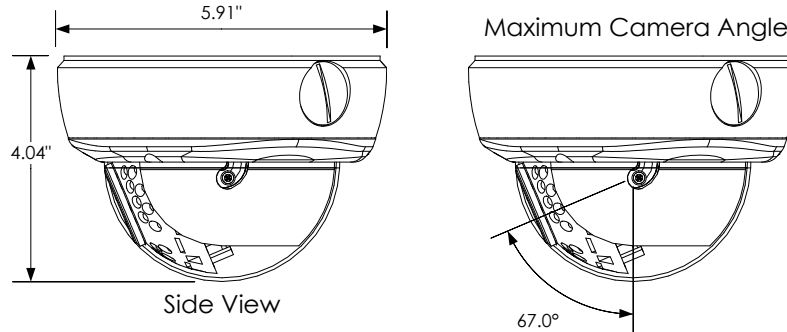

SPECIFICATIONS

Image Sensor	1/3" Color Sony Super HAD II
Number of Pixels	NTSC:768(H)x494(V)
Lens	4~9mm Auto Iris Vari-Focal Lens, Horizontal FOV 60°(W)~30°(T)
Shutter Control	60~1/100,000 sec
Video Test Port	Yes
Auto IRIS	Yes
Auto Electronic Shutter	ON
Auto Gain Control	ON
Back Light Compensation	ON
Auto White Balance	ON
Sync. Mode	Internal Sync
Scanning System	2:1 Interlace
Resolution	550 TV Lines

S/N Ratio	>48dB
Gamma	0.45
Minimum illumination	0.01 Lux color, 0 Lux IR on
IR LED Count	24
IR Range	65 ft.
Smart IR	Yes
Horizontal Sync. Frequency	NTSC: 15.734KHz
Video Output	1.0Vp-p,75ohm
Power Source	12 VDC (500 mA) – Not included
Power Consumption	3.6W 300mA
Operating Temperature	14F-140F
Weather Proof	IP66 Grade
Certifications	CE, FCC, ROHS
Dimensions	4.04" H x 5.91" W

5-Year Limited Warranty

This camera has a 5-Year Limited Warranty. The warranty includes parts and labor repairs on all components found to be defective in material or workmanship under normal conditions of use. This warranty shall not apply to products which have been abused, modified, disassembled or improperly installed. Products to be repaired under this warranty must be returned to Snap AV or a designated service center with prior notification and an assigned return authorization number (RA).